

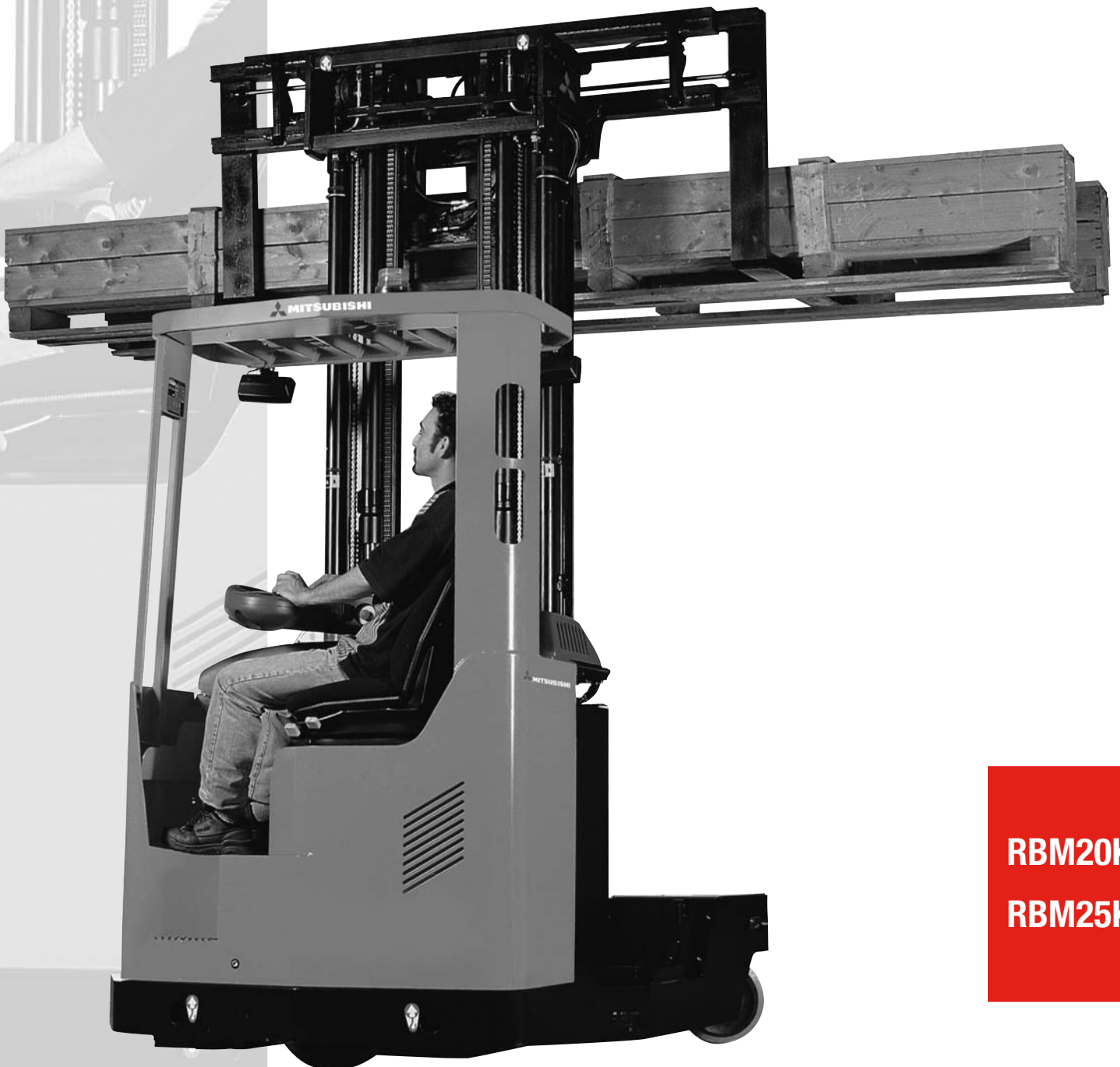

**Multi-Way  
Reach Trucks  
2.0 - 2.5 tonnes**



**RBM20K**

**RBM25K**

Characteristics					
1.1	Manufacturer (abbreviation)			Mitsubishi	Mitsubishi
1.2	Manufacturer's model designation			RBM20K	RBM25K
1.3	Power source: (battery, diesel, LP gas, petrol)			Battery	Battery
1.4	Operator type: pedestrian, (operator)-standing, -seated			Sit-on	Sit-on
1.5	Load capacity	Q	(kg)	2.000	2.500
1.6	Load centre distance	c	(mm)	600	600
1.8	Load wheel axle to fork face (forks lowered)	x	(mm)	(see table)	(see table)
1.9	Wheelbase	y	(mm)	1485	1485
Weight					
2.1	Truck weight with nominal load & maximum battery weight		kg	6550	7300
2.3	Axle loadings without load & with maximum battery weight, drive/load side		kg	2700 / 2x 925	2900 / 2x 950
2.4	Axle loading, mast forward, with nominal load, front/rear (lowest lift height)			850 / 2x 2850	600 / 2x 3350
2.5	Axle loading, mast retracted, with nominal load, front/rear (lowest lift height)			2200 / 2x 2175	2400 / 2x 2450
Wheels, Drive Train					
3.1	Tyres: PT=Power Thane, Vul=Vulkollan, drive/load side			Vul / Vul	Vul / Vul
3.2	Tyre dimensions, drive side		(mm)	285 / 75	285 / 75
3.3	Tyre dimensions, load side		(mm)	343 / 140	343 / 140
3.5	Number of wheels, drive/load side (x=driven)			1x / 4	1x / 4
3.6	Track width (centre of tyres), drive side	b10	(mm)	1410	1410
Dimensions					
4.1	Fork tilt, forwards / backwards	$\alpha/\beta$	°	2 / 6	2 / 6
4.2	Height with mast lowered (see tables)	h1	(mm)	(see table)	(see table)
4.3	Free lift (see tables)	h2	(mm)	(see table)	(see table)
4.4	Lift height (see tables)	h3	(mm)	(see table)	(see table)
4.5	Overall height with mast raised	h4	(mm)	(see table)	(see table)
4.7	Height to top of overhead guard	h6	(mm)	2185	2185
4.8	Seat height	h7	(mm)	1055	1055
4.10	Height of load legs	h8	(mm)	485	485
4.15	Fork height, fully lowered	h13	(mm)	50	50
4.19	Overall length	l1	(mm)	2590	2590
4.20	Length to fork face (includes fork thickness)	l2	(mm)	(see table)	(see table)
4.21	Overall width	b1/b2	(mm)	1700	1700
4.22	Fork dimensions (thickness, width, length)	s / e / l	(mm)	50 / 120 / 1150	50 / 120 / 1150
4.24	Fork carriage width	b3	(mm)	1680	1680
4.25	Outside width over forks (minimum/maximum)	b5	(mm)	560 - 1970	560 - 1970
4.26	Innerwidth of load legs	b4	(mm)	900	900
4.28	Mast reach	l4	(mm)	(see table)	(see table)
4.32	Ground clearance at centre of wheelbase, (forks lowered)	m2	(mm)	80	60
4.33	Working aisle width (Ast) with 1000 x1200 mm pallets, load crosswise	Ast	(mm)	(see table)	(see table)
4.34	Working aisle width (Ast) with 800 x1200 mm pallets, load lengthwise	Ast	(mm)	(see table)	(see table)
4.35	Turning circle radius	Wa	(mm)	1800	1800
4.37	Truck length over load legs	l7	(mm)	1980	1980
Performance					
5.1	Travel speed, with/without load		km/h	10.0 / 10.5	10.0 / 10.5
5.2	Lifting speed, with/without load		m/s	0.23 / 0.43	0.21 / 0.43
5.3	Lowering speed, with/without load		m/s	0.40 / 0.38	0.40 / 0.38
5.4	Reach speed, with/without load		m/s	0.10 / 0.10	0.10 / 0.10
5.8	Maximum gradeability, with/without load		%	8.0 / 12,5	7.0 / 12.0
5.9	Acceleration time (10 metres) with/without load		s	6.0 / 5.6	6.5 / 5.5
5.10	Service brakes (mechanical/hydraulic/electric/pneumatic)			electr.-mech.	electr.-mech.
Electric motors					
6.1	Drive motor capacity (60 min. short duty)		kW	7.5	7.5
6.2	Lift motor output at 15% duty factor		kW	14.0	14.0
6.4	Battery voltage/capacity at 5-hour discharge		V/Ah	48 / 775, 930	48 / 775, 930
6.5	Battery weight		kg	1100, 1300	1100, 1300
Miscellaneous					
8.1	Type of drive control			stepless	stepless



## Sophisticated features, quality workmanship and reliable performance.

### Style & Ergonomics

- spacious, modern and ergonomic operator's compartment for smooth, comfortable operation
- «fly-by-wire» steering and featherlight hydraulic controls ensure effortless work shifts
- the swing-away control console ensures optimum driving comfort
- fully adjustable seat for weight, backrest and driving position
- clearview mast for unobstructed view for the operator

### Exceptional Performance

- smooth and easy handling of long loads in narrow aisles
- impressive mast lift and lower speeds enable high stacking efficiency
- multi-directional travel: forwards, backwards, parallel, sideways, and rotational. Travel modes are controlled by a selection switch

### High Technology

- AC technology for all motors and controllers (drive, pump and steering motors)
- AC drive motor provides powerful acceleration, regenerative braking and stepless modulation of travel speed
- high frequency control unit for the pump results in smooth, jolt-free performance for each individual hydraulic function
- each load wheel has an independent steer motor, controller and brake system for enhanced manoeuvrability
- all wheels turn 360° in either direction for infinite steering precision
- fully programmable functions like speed, acceleration and braking for job-matched performance
- broad selection of built-in diagnostic functions minimise troubleshooting and downtime
- swing open cab concept ensures complete, simple and rapid access for service

### Options available

- lift height indicator or lift height pre-selector
- hinged elbow support for driver
- radio / speaker system
- warning light
- seat head rest.

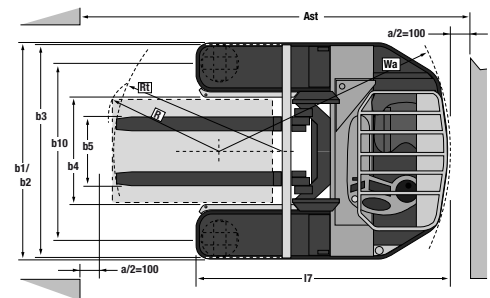
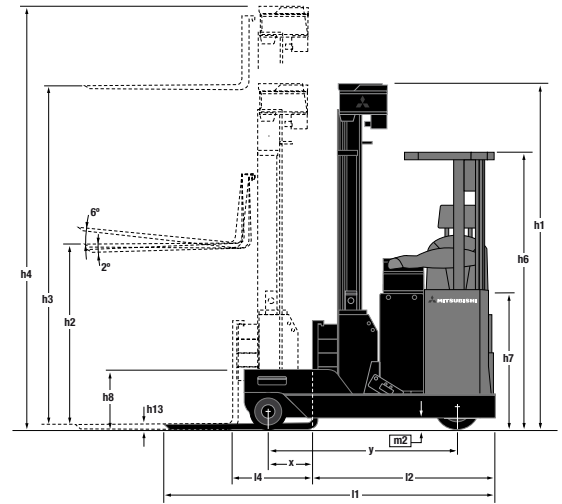

$$\begin{aligned} Ast &= Wa + R + a \\ Ast &= \text{Working aisle width} \\ Wa &= \text{Turning radius} \\ a &= \text{Safety clearance} = 2 \times 100 \text{ mm} \\ R &= \sqrt{(l6 - x)^2 + (l2 / 2)^2} \end{aligned}$$

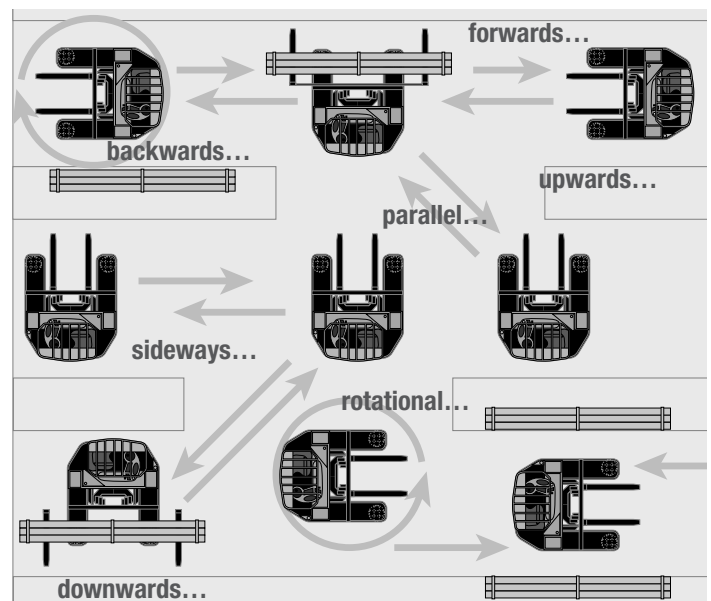

**Mitsubishi Multi-Way Reach Trucks : designed to move and store your goods in all directions, efficiently and safely.**

Mitsubishi RBM20K and RBM25K Multi-Way Reach Trucks are ideally suited for intensive industrial applications. They are particularly productive when required to operate in very narrow aisles or other confined areas.

In addition, they are designed for maximum simplicity of service and routine maintenance. The complete cab swings open allowing unlimited and uncluttered access to all main components and systems.

These models possess a totally programmable controller featuring state-of-the-art electronics. The controller can be programmed to a variety of operating conditions while ensuring low energy consumption and long work shifts.

When you need uncompromised reliability and total directional flexibility, you will find the answer in Mitsubishi's RBM20K and RBM25K Multi-Way Reach Trucks.

**Mast Performance and Capacity**

		RBM20K • RBM25K				
Mast Type	h3+h13 mm	h1 mm	h4 mm	h2+h13 mm	Carriage tilt F/B (°)	
Triplex with free lift	5400	2495	6200	1800	2/6	
	5700	2595	6500	1900	2/6	
	5900	2662	6700	1967	2/6	
	6300	2795	7100	2100	2/6	
	7000	3028	7800	2333	2/6	
	7500	3195	8300	2500	2/6	
	8000	3362	8800	2667	2/6	
	8500	3528	9300	2833	2/6	
	9000	3695	9800	3000	2/6	

h1 = overall lowered height  
h4 = overall extended height  
h2 + h13 = free lift

RBM20K / RBM25K • Integrated fork spreader with tilt							
Chassis width (mm)	Battery current (Ah)	Battery weight (kg)	Ast*(Ast3*) 4.33 (mm)	Ast*(Ast3*) 4.34 (mm)	I4 4.28 (mm)	I2 4.20 (mm)	x 1.8 (mm)
1700	800	1100	2885 (2650)	2940 (2850)	620	1440	350
1700	960	1300	2925 (2705)	2990 (2906)	565	1495	295

\* Ast = Wa + R + 200 (Ast3 = Wa - X + I6 + 200)



WEGM0208 (04/09) ok  
© 2009 MCFE  
Printed in The Netherlands

[mitforklift@mcf.nl](mailto:mitforklift@mcf.nl)  
[www.mitforklift.com](http://www.mitforklift.com)

NOTE: Performance specifications may vary depending on standard manufacturing tolerances, vehicle condition, types of tyres, floor or surface conditions, applications or operating environment. Trucks may be shown with non-standard options. Specific performance requirements and locally available configurations should be discussed with your distributor of Mitsubishi forklift trucks. Mitsubishi follows a policy of continual product improvement. For this reason, some materials, options and specifications could change without notice.